

# PROTECT CARE



## + Static and mobile clear Plexiglas® screens

PROTECT partitioning screens are ideal for installing in healthcare settings (laboratories, vaccination sites, etc.) to ensure the protection of patients. They can also be deployed in waiting areas, dining spaces, offices or meeting rooms. These screens come into their own wherever safe physical distancing and the maintenance of inter-personal visual contact is required. And since they are made from Plexiglas®, they are easy to sanitise and keep clean.

5 mm thick transparent  
Plexiglas® screen

White metal  
frame

Easy to maintain  
and disinfect



Mobile screen

Frame mounted on black ABS  
castors, 2 with brakes

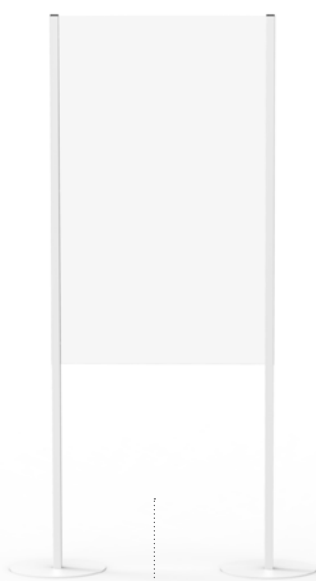

Part-glazed screen

Frame on static feet



Static screen

Frame on static feet



Discover our health protection range « PROTECT »  
at [www.eol-group.net](http://www.eol-group.net)



EUROPEAN OFFICE FURNITURE  
MANUFACTURER  
[www.eol-group.net](http://www.eol-group.net)

# OVERVIEW & PRICES

① Mobile screen

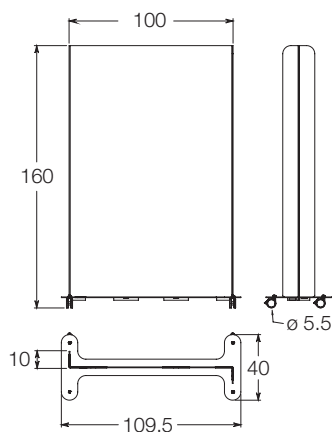

② Static screen

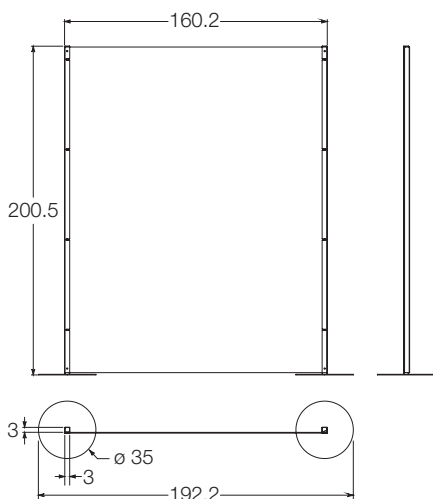

③ Part-glazed screen

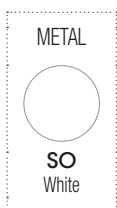
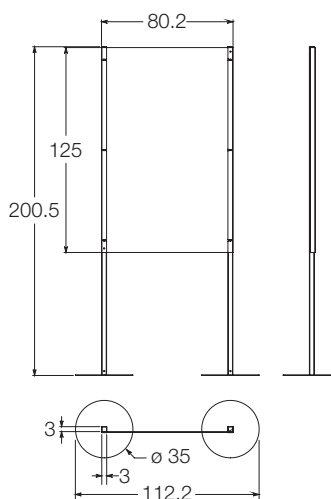

## PROTECT CARE

- ① Mobile screen
- ② Static screen
- ③ Part-glazed screen

Overall dim.: W. 109.5 x H. 160 cm  
 Overall dim.: W. 192.2 x H. 200.5 cm  
 Overall dim.: W. 112.2 x H. 200.5 cm

Ref.	RRP excl VAT
6 736 058 PV SO	€ 484
6 736 060 PV SO	€ 589
6 736 027 PV SO	€ 330

LEAD TIME : 1 to 3 weeks



**Maintenance:**  
 Use everyday cleaning products (soap, glass cleaner, diluted bleach 10%).  
 Resistant to hydroalcoholic gels when wiped down afterwards.



Discover our health protection range « PROTECT »  
 at [www.eol-group.net](http://www.eol-group.net)



EUROPEAN OFFICE FURNITURE  
 MANUFACTURER  
[www.eol-group.net](http://www.eol-group.net)